

No.	PARTS NAME	Check	MATERIAL	Check	MATERIAL	Check	MATERIAL	Q'ty	REMARK
			STANDARD		SEMI STANDARD		SEMI STANDARD		
1	BODY		SCS13A		SCS14A		SCS16A	1	
2	DISC		SCS13A		SCS14A		SCS16A	1	
3	SET RING		SCS13A		SCS14A		SCS16A	1	
4	SEAT RING		PTFE (WHITE)		PTFE (WHITE)		PTFE (WHITE)	1	*1
			PTFE (BLACK)		PTFE (BLACK)		PTFE (BLACK)		
5	-		-		-		-	-	
6	STEM		SUS304		SUS316		SUS316L	1set	
7	GLAND		SCS14A		SCS14A		SCS14A	1	
8	BUSH		SUS316+PTFE		SUS316+PTFE		SUS316+PTFE	1set	
9	PACKING WASHER		SUS304		SUS316		SUS316L	1	
10	GLAND PACKING		PTFE		PTFE		PTFE	1set	
11	COVER		SCS13A		SCS14A		SCS16A	1	
12	GASKET		NON-ASBESTOS		NON-ASBESTOS		NON-ASBESTOS	1	
13	TAPER PIN		SUS304		SUS316		SUS316L	1set	
14	GLAND BOLT		SUS304		SUS316		SUS316	2	
15	SPRING WASHER		SUS304		SUS316		SUS316	2	
16	SET PIN		SUS420J2		SUS420J2		SUS420J2	2	
17	DRAW OUT SCREW		SUS304		SUS316		SUS316	2	
18	COVER BOLT		SCM435 (PLATED)		SCM435 (PLATED)		SCM435 (PLATED)	4	
19	SPRING WASHER		SUS304		SUS316		SUS316	4	
20	SPACER YOKE		SCS13A		SCS13A		SCS13A	2	
21	LEVER		FCMB		FCMB		FCMB	1	
22	INDICATOR		SS400 (PLATED)		SS400 (PLATED)		SS400 (PLATED)	1	
23	BOLT		SUS304		SUS304		SUS304	2	
24	WASHER		SUS304		SUS304		SUS304	2	
25	NUT		SUS304		SUS304		SUS304	2	
26	SPRING WASHER		SUS304		SUS304		SUS304	2	
27	SPRING PIN		SUS420J2		SUS420J2		SUS420J2	2	
28	BOLT		SUS304		SUS304		SUS304	1	
29	SPRING WASHER		SUS304		SUS304		SUS304	1	

NOTE *1) IN CASE OF STEAM PTFE (WHITE) : WORKING TEMP. Max. 150°C

Check	SIZE	d	L	g	H	H1	H2	A	LEVER SIZE	WEIGHT (About)
	50mm	40	43	92	242	64	178	160	160L	3.7Kg
	65mm	55	46	108	262	74	188	160	160L	4.2Kg

SIZE	JIS5K			JIS10K		
	C	N	M	C	N	M
50mm	105	4	M12	120	4	M16
65mm	130	4	M12	140	4	M16

日付 DATE	Oct. 22. 2007	尺度 SCALE	FREE	製造番号 MFG. No.	
最高使用圧力 MAX. WORKING PRESS.	1.0 MPa Pe	使用温度 *1 WORKING TEMP.	-29~232 °C	形式 TYPE	MODEL 541T (K)
耐圧試験 SHELL TEST	1.5 MPa Pe	試験流体 TEST FLUID	WATER	名称 NAME	BUTTERFLY VALVES WITH LEVER OPERATOR
弁座試験 SEAT TEST	1.1 MPa Pe	許容漏れ LEAKAGE	0		
作成 DRAWN	検討 CHECKED	承認 APPROVED		株式会社 オークエム OKUMURA ENGINEERING corp.	
図面番号 DRAWING No.	541T LA 0620 E			Hd-lan975 SYONINST	

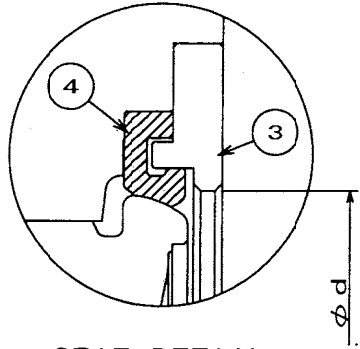

SEAT DETAIL

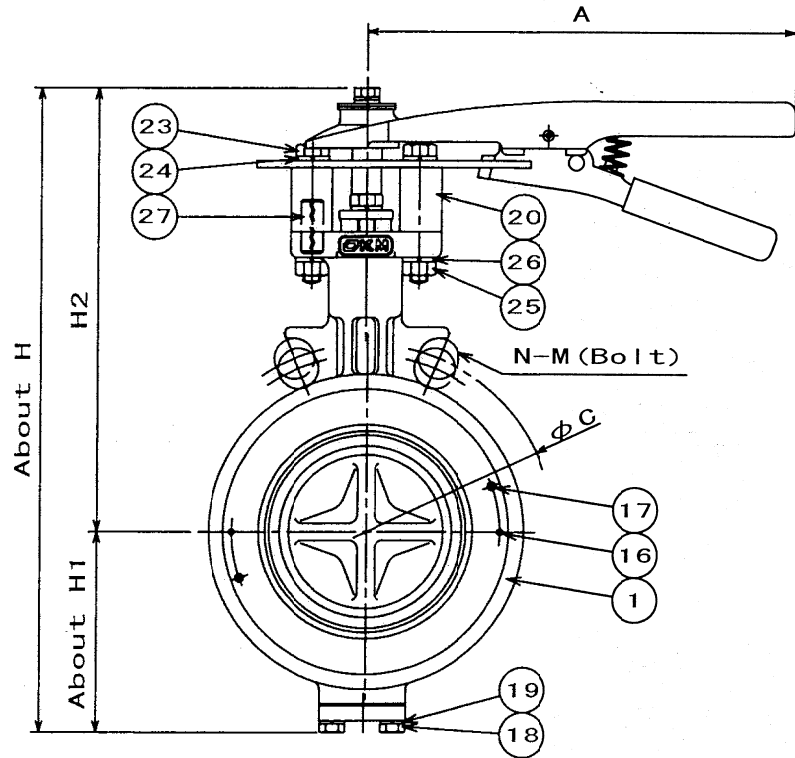
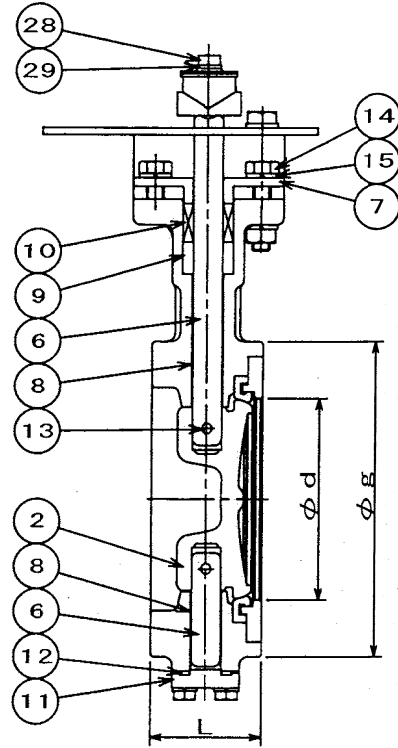
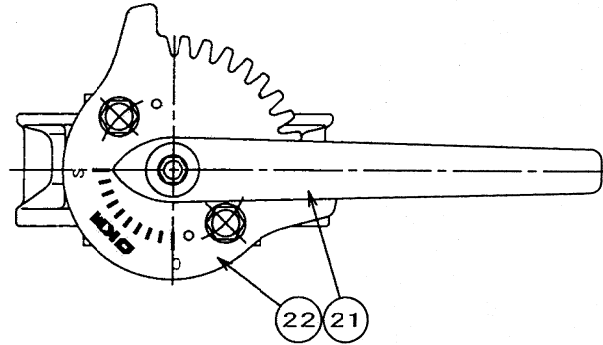

No.	PARTS NAME	Check	MATERIAL	Check	MATERIAL	Check	MATERIAL	Q'ty	REMARK
			STANDARD		SEMI STANDARD		SEMI STANDARD		
1	BODY		SCS13A		SCS14A		SCS16A	1	
2	DISC		SCS13A		SCS14A		SCS16A	1	
3	SET RING		SCS13A		SCS14A		SCS16A	1	
4	SEAT RING		PTFE (WHITE)		PTFE (WHITE)		PTFE (WHITE)	1	*1
			PTFE (BLACK)		PTFE (BLACK)		PTFE (BLACK)		
5	-		-		-		-	-	
6	STEM		SUS304		SUS316		SUS316L	1set	
7	GLAND		SCS14A		SCS14A		SCS14A	1	
8	BUSH		SUS316+PTFE		SUS316+PTFE		SUS316+PTFE	1set	
9	PACKING WASHER		SUS304		SUS316		SUS316L	1	
10	GLAND PACKING		PTFE		PTFE		PTFE	1set	
11	COVER		SCS13A		SCS14A		SCS16A	1	
12	GASKET		NON-ASBESTOS		NON-ASBESTOS		NON-ASBESTOS	1	
13	TAPER PIN		SUS304		SUS316		SUS316L	1set	
14	GLAND BOLT		SUS304		SUS316		SUS316	2	
15	SPRING WASHER		SUS304		SUS316		SUS316	2	
16	SET PIN		SUS420J2		SUS420J2		SUS420J2	2	
17	DRAW OUT SCREW		SUS304		SUS316		SUS316	2	
18	COVER BOLT		SCM435 (PLATED)		SCM435 (PLATED)		SCM435 (PLATED)	4	
19	SPRING WASHER		SUS304		SUS316		SUS316	4	
20	SPACER YOKE		SCS13A		SCS13A		SCS13A	2	
21	LEVER		FCMB		FCMB		FCMB	1	
22	INDICATOR		SS400 (PLATED)		SS400 (PLATED)		SS400 (PLATED)	1	
23	BOLT		SUS304		SUS304		SUS304	2	
24	WASHER		SUS304		SUS304		SUS304	2	
25	NUT		SUS304		SUS304		SUS304	2	
26	SPRING WASHER		SUS304		SUS304		SUS304	2	
27	SPRING PIN		SUS420J2		SUS420J2		SUS420J2	2	
28	BOLT		SUS304		SUS304		SUS304	1	
29	SPRING WASHER		SUS304		SUS304		SUS304	1	

Check	SIZE	d	L	g	H	H1	H2	A	LEVER SIZE	WEIGHT (About)
	80mm	70	46	127	283	84	199	200	200L	4.9Kg
	100mm	94	52	147	303	94	209	200	200L	5.7Kg
	125mm	119	56	180	359	110	248	360	360L	10.5Kg
	150mm	144	56	209	388	124	263	360	360L	11.8Kg

SIZE	JIS5K			JIS10K		
	C	N	M	C	N	M
80mm	145	4	M16	150	8	M16
100mm	165	8	M16	175	8	M16
125mm	200	8	M16	210	8	M20
150mm	230	8	M16	240	8	M20

NOTE *1) IN CASE OF STEAM PTFE (WHITE) : WORKING TEMP. Max. 150°C

日付 DATE	Oct. 22. 2007	尺度 SCALE	FREE	製造番号 MFG. No.	
最高使用圧力 MAX. WORKING PRESS.	1.0 MPa P _e	使用温度 *1 WORKING TEMP.	-29~232 °C	形式 TYPE	MODEL 541T (K)
耐圧試験 SHELL TEST	1.5 MPa P _e	試験流体 TEST FLUID	WATER	名称 NAME	BUTTERFLY VALVES WITH LEVER OPERATOR
弁座試験 SEAT TEST	1.1 MPa P _e	許容漏れ LEAKAGE	0		
作成 DRAWN	検討 CHECKED	承認 APPROVED		 株式会社 オークエム OKUMURA ENGINEERING corp.	
				図面番号 DRAWING No.	541T LA 0621 E
					Hd-1an975 SYONINST