

SIZE	d	L1	L2	g	H	H1	H2	H3	T	A	B	W	GEAR SIZE	MASS (About)
350A	336	92	95.5	389	657.5	289	330	38.5	69	335	73.9	315	63K	72kg

SIZE	JIS5K			JIS10K			ASME125Lb/150Lb		
	C	N	h	C	N	h	C	N	h
350A	435	4/12	M22	445	4/16	M22	476.3	4/12	1-8UNC

Table 1	Table 2	SIZE	PARTS No.	INSTALLATION
FCD450 PLATED	NBR #1			
SCS13	EPDM#2			
SCS14				

INSTALLATION

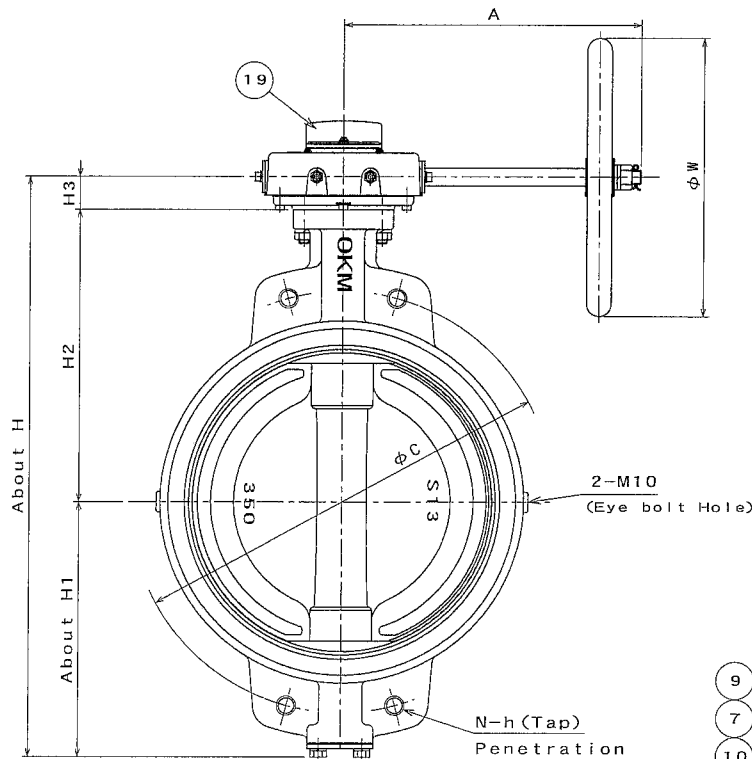
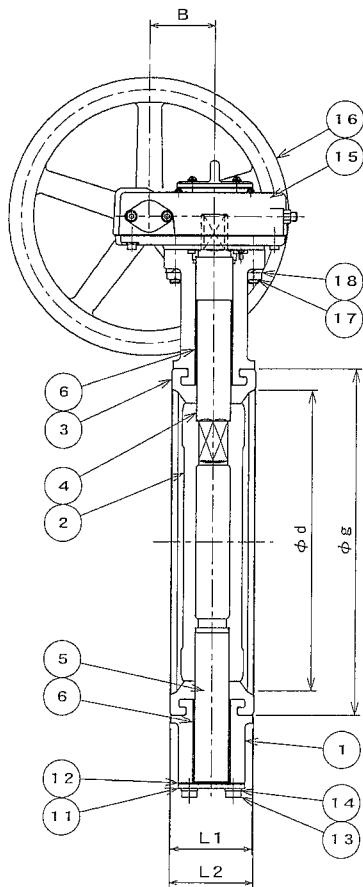
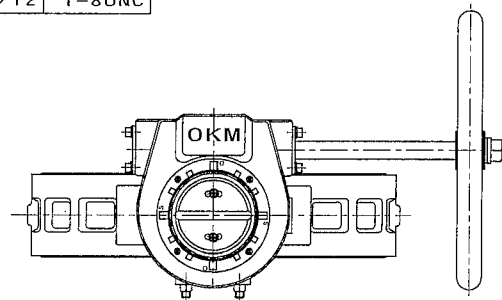
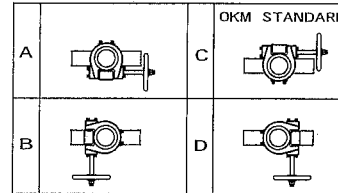

NECK DETAIL

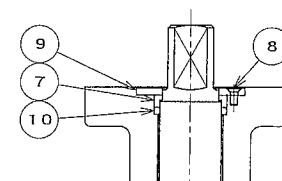

製番 MFG. NO.				
名称及形式 NAME AND TYPE		MODEL 615X (350A) BUTTERFLY VALVE WITH Type A WORM GEAR OPERATOR		
番号 NO.	部品名称 PARTS NAME	材質 MATERIAL	数量 Q. ty	備考 REMARKS
1	BODY	FC250	1	
2	DISC	See Table 1	1	
3	SEAT RING	See Table 2	1	
4	UPPER STEM	SUS420J2	1	
5	LOWER STEM	SUS420J2	1	
6	BUSH	PLASTIC	1set	
7	NECK BUSH	PLASTIC	1	
8	SCREW	SWRM	4	PLATED
9	SET PLATE	SS400	1	PLATED
10	O-RING	NBR	1	
11	COVER	SS400	1	PLATED
12	GASKET	NON-ASBESTOS	1	
13	COVER BOLT	SWRCH	4	PLATED
14	SPRING WASHER	SWRH	4	PLATED
15	GEAR BOX	FC250	1	
16	HAND WHEEL	FC250	1	
17	STUD BOLT, NUT	SGD SWRCH	4	PLATED
18	SPRING WASHER	SWRH	4	PLATED
19	INDICATOR	FC250	1	△
20				
21				
22				
23				
24				
25				
日付 DATE	NOV. 21, 2003	尺度 SCALE	FREE	
使用压力 WORKING PRESSURE	Max 0.5/1.0 MPa Pe	使用温度 WORKING TEMP.	t1: -10~70 °C t2: -20~120 °C	
耐压試験 SHELL TEST	1.5 MPa Pe	試験流体 TEST FLUID	WATER	
弁座試験 SEAT TEST	0.55/1.1 MPa Pe	許容漏れ LEAKAGE	0 %	
作成 DRAWN	検討 CHECKED	承認 APPROVED		
S.Y		FEB. 16, 2007		
OKM 株式会社 オーケーエム OKUMURA ENGINEERING corp.		FLOP.No.		
図面番号 DRAWING NO.	615X GB 4047 EB		HD-LAN975	

△ NOV. 20, 2009
△ FEB. 16, 2007

SIZE	d	L1	L2	g	H	H1	H2	H3	T	A	B	W	GEAR SIZE	MASS (About)
400A	390	102	105.5	448	737	322	370	45	76	320	97.1	315	100K	94kg
450A	439	114	117.5	504	790	345	400	45	100	320	97.1	315	100K	116kg
500A	490	127	131	554	872	379	440	53	108	331	114.5	355	160K	167kg
550A	540	154	158	608	933	410	470	53	126	392	114.5	450	160K	199kg
600A	589	154	158	658	1003	445	505	53	134	392	114.5	450	160K	233kg

SIZE	JIS5K				JIS10K				ASME125Lb/150Lb			
	C	N	h	Depth (Min)	C	N	h	Depth (Min)	C	N	h	Depth (Min)
400A	495	4/16	M22	22	510	4/16	M24	24	539.8	4/16	1-8UNC	1
450A	555	4/16	M22	22	565	4/20	M24	24	577.9	4/16	1 1/8 -8UN	1 1/8
500A	605	4/20	M22	22	620	4/20	M24	24	635.0	4/20	1 1/8 -8UN	1 1/8
550A	665	4/20	M24	24	680	4/20	M30	30	-	-	-	-
600A	715	4/20	M24	24	730	4/24	M30	30	749.3	4/20	1 1/4 -8UN	1 1/4

Table 1	Table 2	SIZE	PARTS No.	INSTALLATION
FCD450 PLATED	NBR *1			
SCS13	EPDM*2			
SCS14				

INSTALLATION

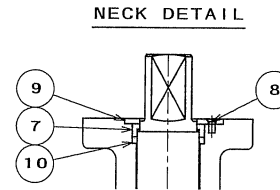
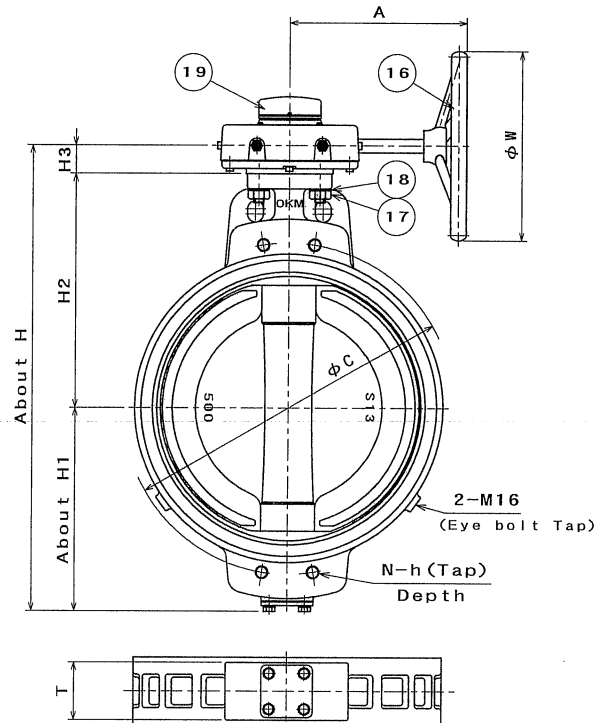
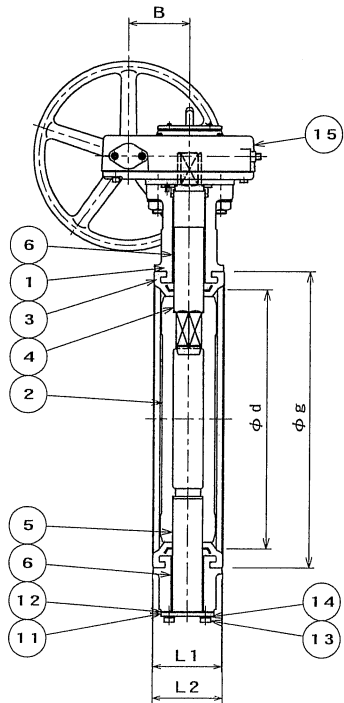
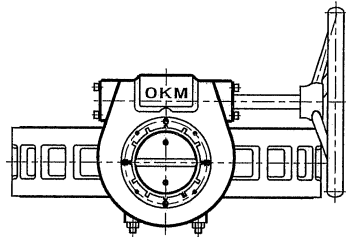
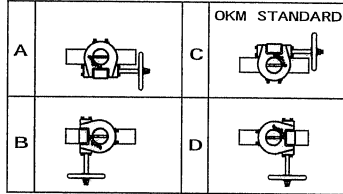

製番 MFG. NO.

名称及形式 MODEL 615X (400A~600A)
NAME AND TYPE BUTTERFLY VALVES WITH
Type A WORM GEAR OPERATOR

番号 NO.	部品名称 PARTS NAME	材質 MATERIAL	数量 Q. ty	備考 REMARKS
1	BODY	FC250	1	
2	DISC	See Table 1	1	
3	SEAT RING	See Table 2	1	
4	UPPER STEM	SUS420J2	1	
5	LOWER STEM	SUS420J2	1	
6	BUSH	PLASTIC	1set	
7	NECK BUSH	PLASTIC	1	
8	SCREW	SWRM	4	PLATED
9	SET PLATE	SS400	1	PLATED
10	O-RING	NBR	1	
11	COVER	SS400	1	PLATED
12	GASKET	NON-ASBESTOS	1	
13	COVER BOLT	SWRCH	4	PLATED
14	SPRING WASHER	SWRH	4	PLATED
15	GEAR BOX	FC250	1	
16	HAND WHEEL	FC250	1	
17	STUD BOLT, NUT	SGD SWRCH	4	PLATED
18	SPRING WASHER	SWRH	4	PLATED
19	INDICATOR	FC250	1	
20				
21				
22				
23				
24				
25				

日付 DATE OCT. 16, 2012 尺 度 SCALE FREE

使用圧力 WORKING PRESSURE Max 0.5/1.0 MPa Pe 使用温度 WORKING TEMP. #1: -10~70 °C #2: -20~120 °C

耐圧試験 SHELL TEST 1.5 MPa Pe 試験流体 TEST FLUID WATER

弁座試験 SEAT TEST 0.55/1.1 MPa Pe 許容漏れ LEAKAGE 0 %

作成 DRAWN M.H. 検 討 CHECKED T.H. 承認 APPROVED O.K.

株式会社 オークエム OKUMURA ENGINEERING corp.

図面番号 DRAWING NO. 615X GB 5496 E FLOP.No. HD