

10TL-1-04

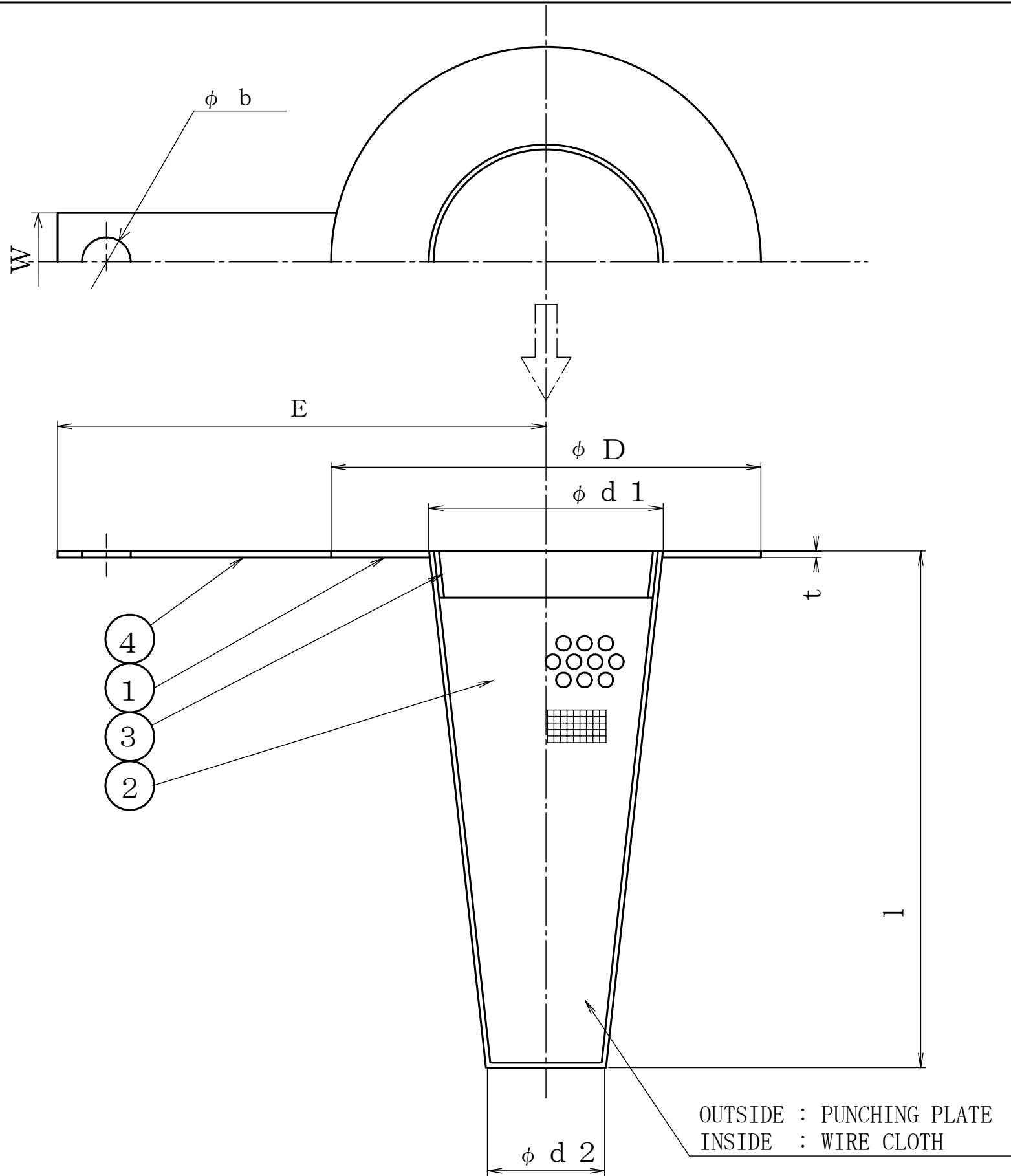

SIZE	d 1	d 2	t	D	l	E	W	b	WEIGHT Kg
25	1	24	2	72	80	90	20	6	
32	1 ¹ / ₄	30	2	82	90	95	20	6	
40	1 ¹ / ₂	36	2	87	100	100	20	6	
50	2	48	2	102	120	120	20	6	
65	2 ¹ / ₂	60	2	122	140	140	20	6	
80	3	72	2	132	165	150	20	6	
100	4	95	2	157	225	160	20	6	
125	5	118	3	188	255	180	25	6	
150	6	142	3	218	315	200	25	6	
200	8	188	3	268	400	230	25	6	
250	10	235	3	330	525	260	25	6	
300	12	280	3	375	600	300	25	6	

SCREEN

	MESH
	20 MESH
	40 MESH
	60 MESH
	80 MESH
	100 MESH

No	NAME OF PART	MATERIAL	Q.T.Y	REMARKS
4	HANDLE	SUS304	1	
3	LINER	SUS304	1	
2	SCREEN	SUS304	1	
1	BODY	SUS304	1	

NAME 10K CONE TYPE
TEMPORARY STRAINER

FLUID		TEST PRESSURE	BODY	(HYD) MPaG
				(AIR) MPaG
DESIGN PRESSURE	MPaG		SEAT	(HYD) MPaG
				(AIR) MPaG
DESIGN TEMPERATURE	°C			(HYD) MPaG
				(AIR) MPaG

DRAWING No _____ MODEL No 10TL-1-04

DATE	A. P	C. K	D. S	D. W
NOV. 16, 2006	MORITA	MORITA	MORITA	HISAKA

MM THREE-M INDUSTRY CO.,LTD.

No	DESCRIPTION	DATE	A. P	C. K	D. W
REVISIONS					