

# 10TL-2-04

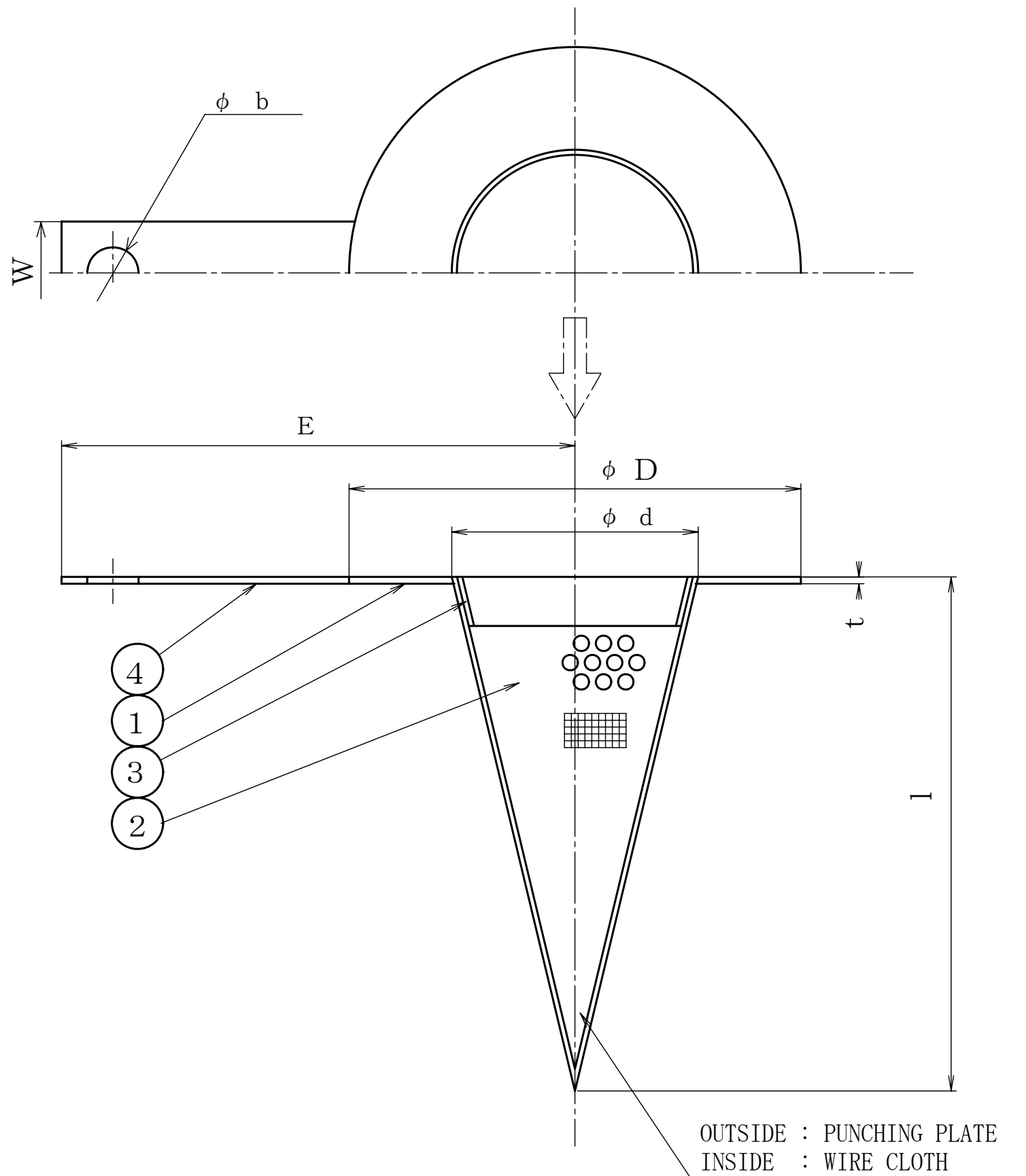

SIZE	d	t	D	l	E	W	b	WEIGHT Kg
25	1	24	2	72	80	90	20	6
32	1 1/4	30	2	82	90	95	20	6
40	1 1/2	36	2	87	100	100	20	6
50	2	48	2	102	120	120	20	6
65	2 1/2	60	2	122	140	140	20	6
80	3	72	2	132	165	150	20	6
100	4	95	2	157	225	160	20	6
125	5	118	3	188	255	180	25	6
150	6	142	3	218	315	200	25	6
200	8	188	3	268	400	230	25	6
250	10	235	3	330	525	260	25	6
300	12	280	3	375	600	300	25	6

### SCREEN

	MESH
	20 MESH
	40 MESH
	60 MESH
	80 MESH
	100 MESH

No	NAME OF PART	MATERIAL	Q.T.Y	REMARKS
4	HANDLE	SUS304	1	
3	LINER	SUS304	1	
2	SCREEN	SUS304	1	
1	BODY	SUS304	1	

NAME 10K CONE TYPE

TEMPORARY STRAINER

FLUID	MPaG	TEST PRESSURE	BODY	(HYD) MPaG
			SEAT	(AIR) MPaG
DESIGN PRESSURE	MPaG			(HYD) MPaG
DESIGN TEMPERATURE	°C			(AIR) MPaG

DRAWING No \_\_\_\_\_ MODEL No 10TL-2-04

DATE	A. P	C. K	D. S	D. W
SEP. 13, 2005	MORITA	MORITA	MORITA	HISAKA

**MM THREE-M INDUSTRY CO.,LTD.**

No	DESCRIPTION	DATE	A. P	C. K	D. W
1	Deleted size 15A and 20A	NOV. 16, '06	HISAKA	HISAKA	HISAKA

REVISIONS