

10FUL-14A

SIZE	d	L	FLANGED								d0	l	H	W1	W2
			D	C	g	f	t	N	h						
15	1/2	20	156	95	70	51	1	12	4	15	33	70	112	R3/8	R3/8
20	3/4	20	160	100	75	56	1	14	4	15	33	70	112	R3/8	R3/8

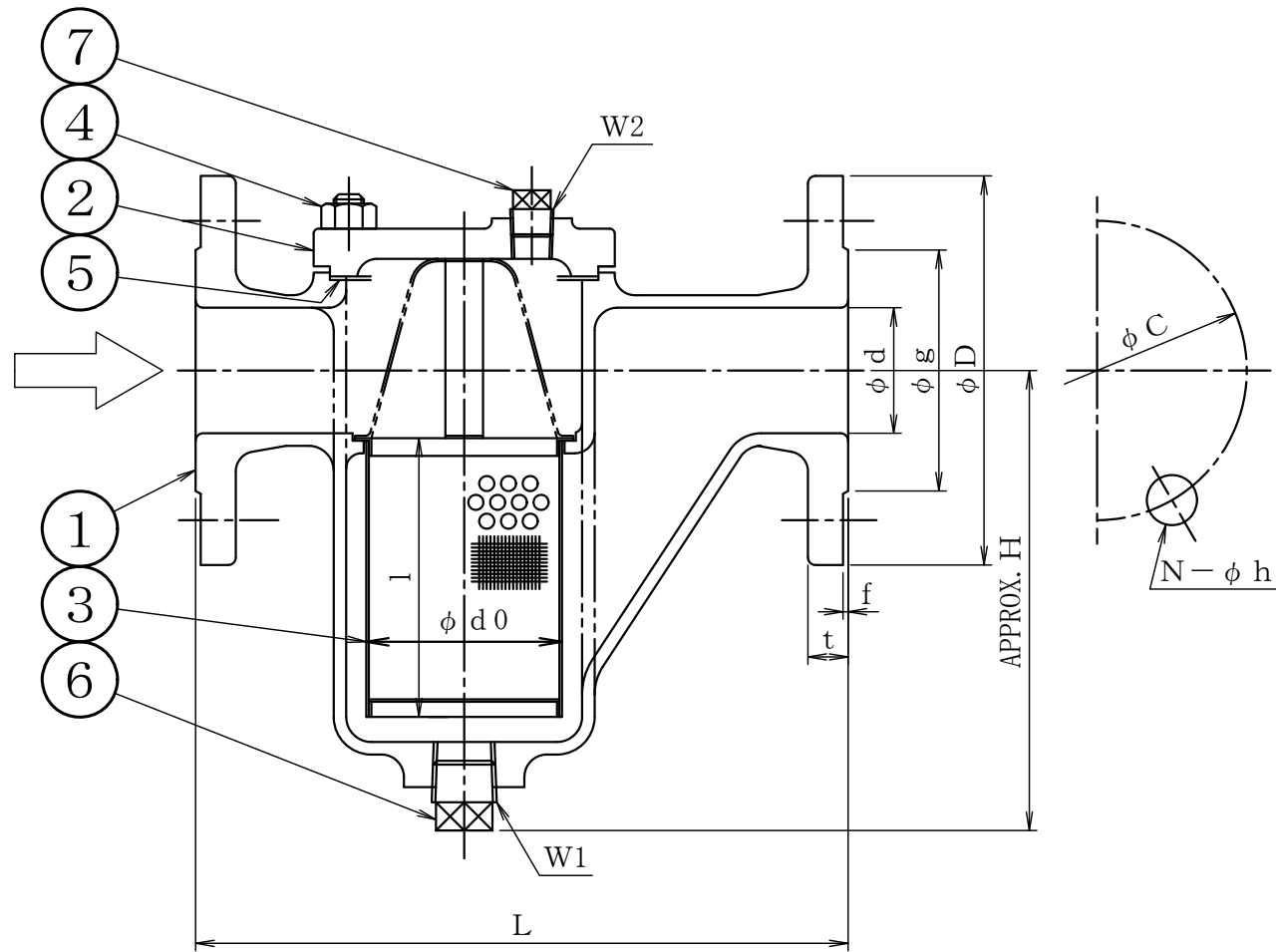
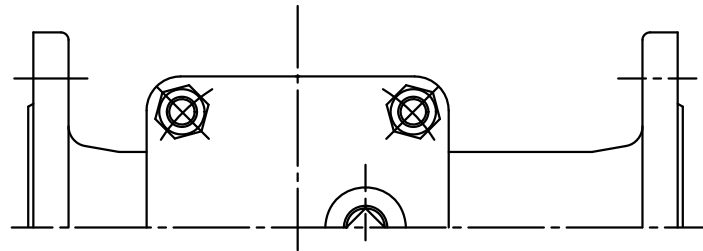

SCREEN

	MESH
	20 MESH
	40 MESH
	60 MESH
	80 MESH
	100 MESH

No	NAME OF PART	MATERIAL	Q.T.Y	REMARKS
7	VENT PLUG	SUS316	1	
6	DRAIN PLUG	SUS316	1	
5	GASKET	T#9007-G20	1	
4	BOLT NUT	SUS304	SET	
3	SCREEN	SUS316	1	
2	COVER	SCS14A	1	
1	BODY	SCS14A	1	

NAME 10K
FLANGED U TYPE STRAINER

FLUID		TEST PRESSURE	BODY	(HYD) 1.5 MPaG
			SEAT	(AIR) MPaG
DESIGN PRESSURE	1.0 MPaG			(HYD) MPaG
				(AIR) MPaG
DESIGN TEMPERATURE	150 °C			(HYD) MPaG
				(AIR) MPaG

DRAWING No _____ MODEL No 10FUL-14A

DATE	A. P	C. K	D. S	D. W
FEB. 24, 2012	MORITA	MORITA	MORITA	HORIE

No	DESCRIPTION	DATE	A. P	C. K	D. W
REVISIONS					

10FUL-14A

SIZE	d	L	FLANGED							d0	l	H	W1	W2	
			D	C	g	f	t	N	h						
25	1	25	180	125	90	67	1	14	4	19	43	80	130	R1/2	R3/8

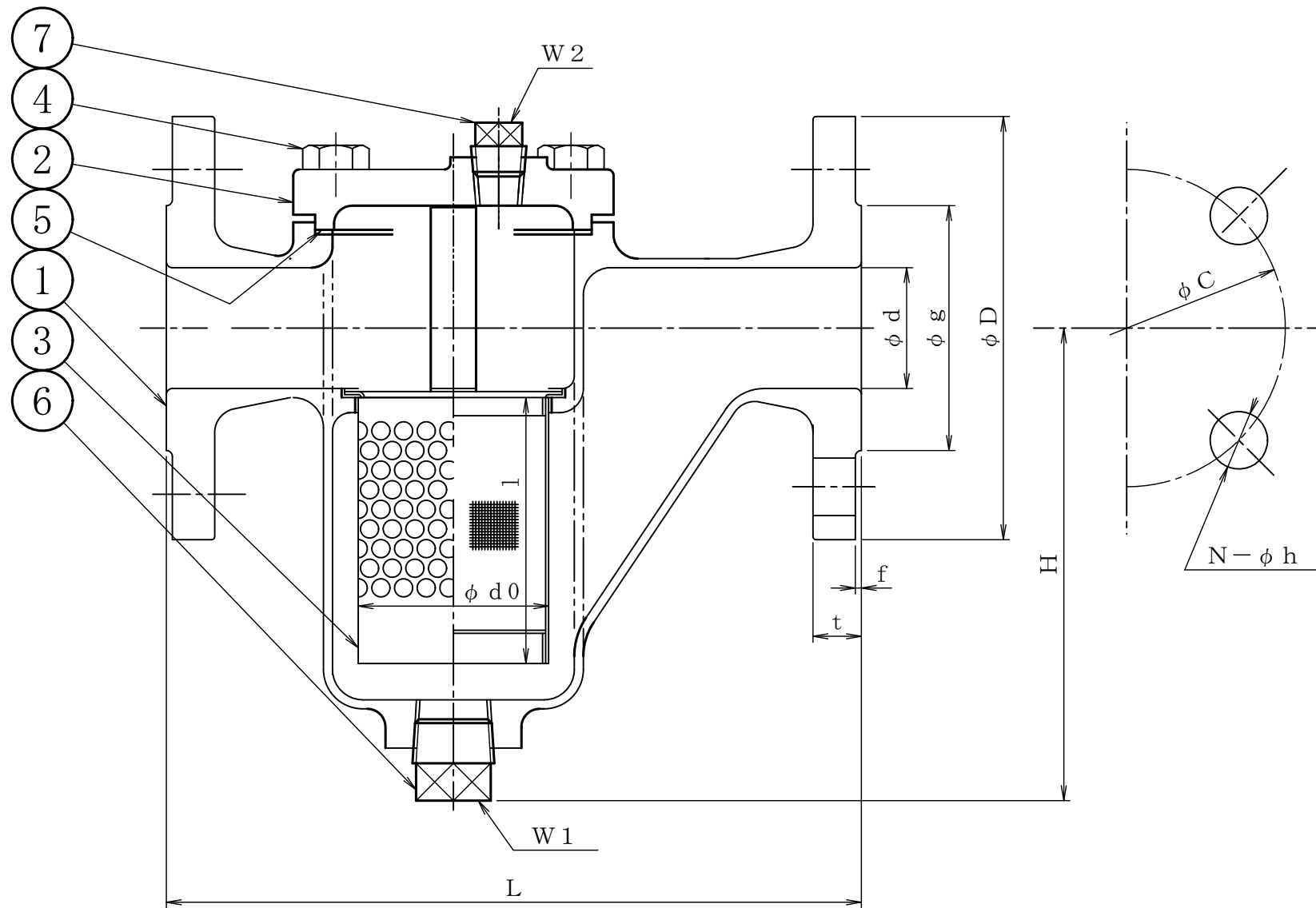
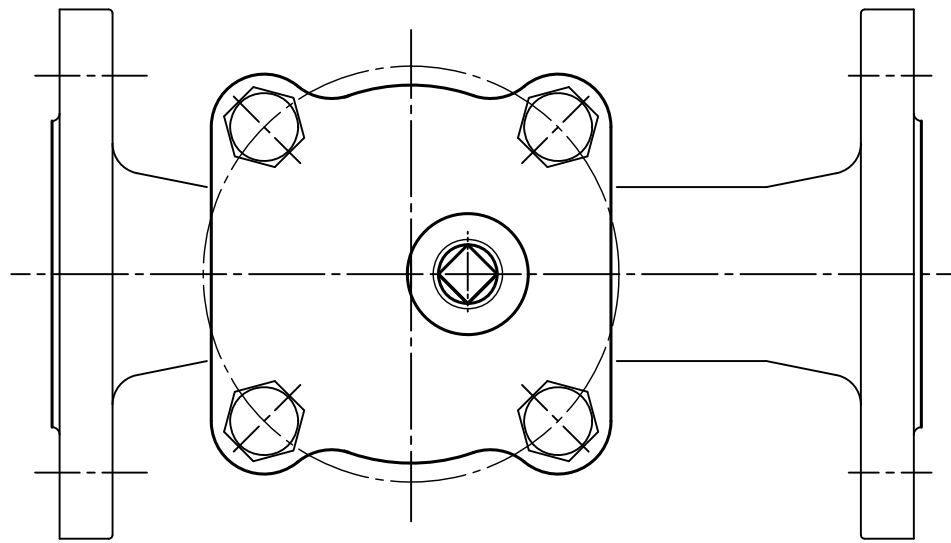

SCREEN

	MESH
	20 MESH
	40 MESH
	60 MESH
	80 MESH
	100 MESH

No	NAME OF PART	MATERIAL	Q.T.Y	REMARKS
7	VENT PLUG	SUS316	1	
6	DRAIN PLUG	SUS316	1	
5	GASKET	T#9007-G20	1	
4	BOLT	SUS304	4	
3	SCREEN	SUS316	1	
2	COVER	SCS14A	1	
1	BODY	SCS14A	1	

NAME 10K
FLANGED U TYPE STRAINER

FLUID	TEST PRESSURE	TEST PRESSURE	BODY	SEAT
(HYD)	1.5 MPaG	(HYD)	(HYD)	(HYD)
(AIR)	MPaG	(AIR)	(AIR)	(AIR)
(HYD)	MPaG	(HYD)	(HYD)	(HYD)
(AIR)	MPaG	(AIR)	(AIR)	(AIR)

DRAWING No _____ MODEL No 10FUL-14A

DATE	A. P	C. K	D. S	D. W
FEB. 24, 2012	MORITA	MORITA	MORITA	HORIE

MM THREE-M INDUSTRY CO.,LTD.

No	DESCRIPTION	DATE	A. P	C. K	D. W
REVISIONS					

10FUL-14A

SIZE	d	L	FLANGED								d0	l	H	H1	W1	W2
			D	C	g	f	t	N	h							
32	1 1/4	40	230	135	100	76	2	16	4	19	63	90	158	-	R3/4	R3/8
40	1 1/2	40	230	140	105	81	2	16	4	19	63	90	158	-	R3/4	R3/8
50	2	50	260	155	120	96	2	16	4	19	78	110	183	-	R3/4	R3/8
65	2 1/2	65	280	175	140	116	2	18	4	19	90	130	216	-	R1	R3/8
125	5	125	490	250	210	182	2	20	8	23	162	250	400	204	R1	R1/2
150	6	150	560	280	240	212	2	22	8	23	202	300	500	218	R1	R1/2

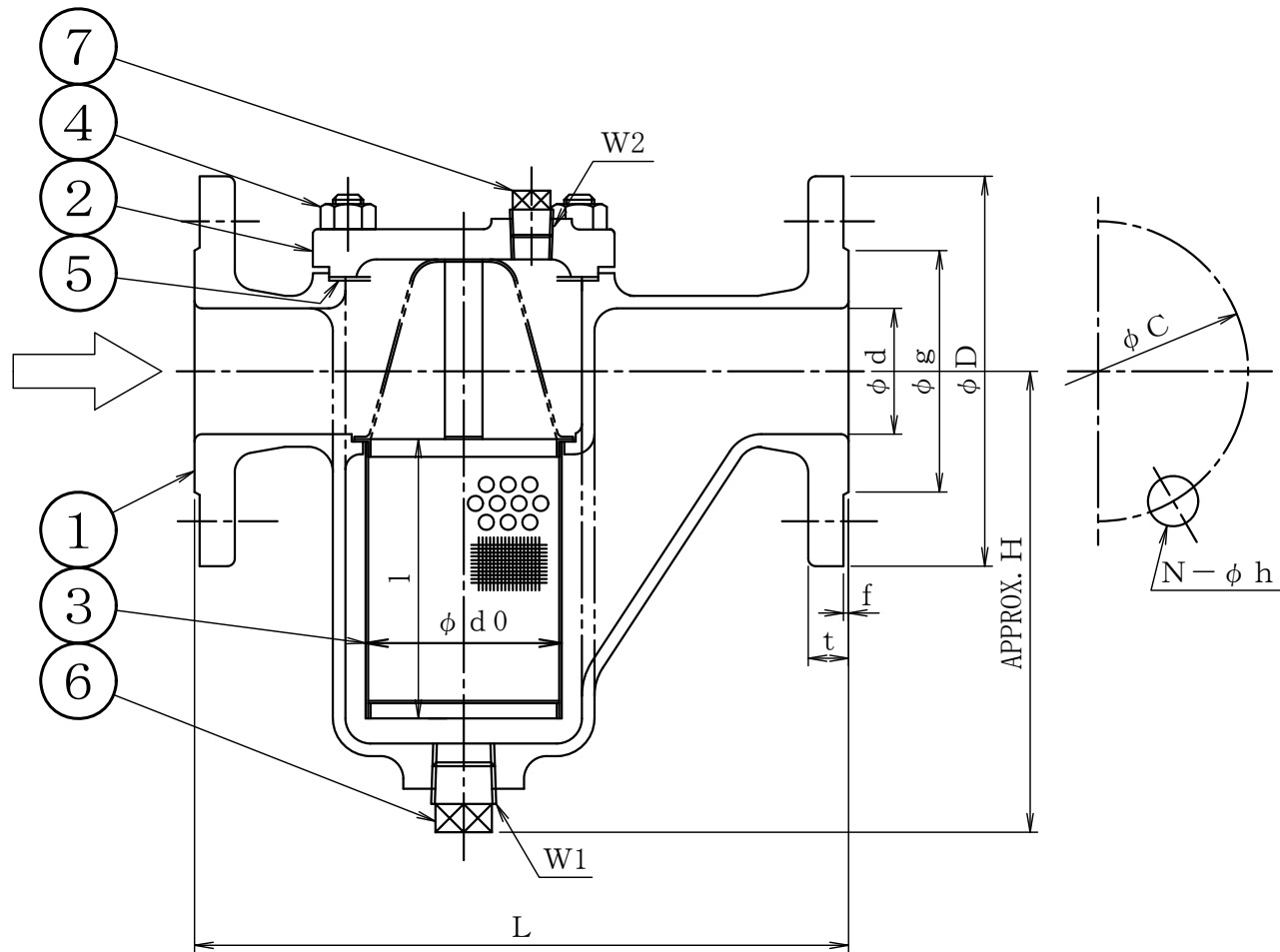
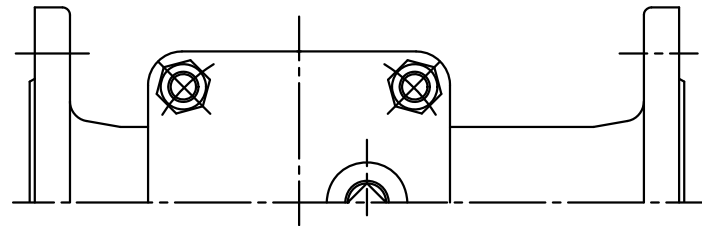

32A~65A

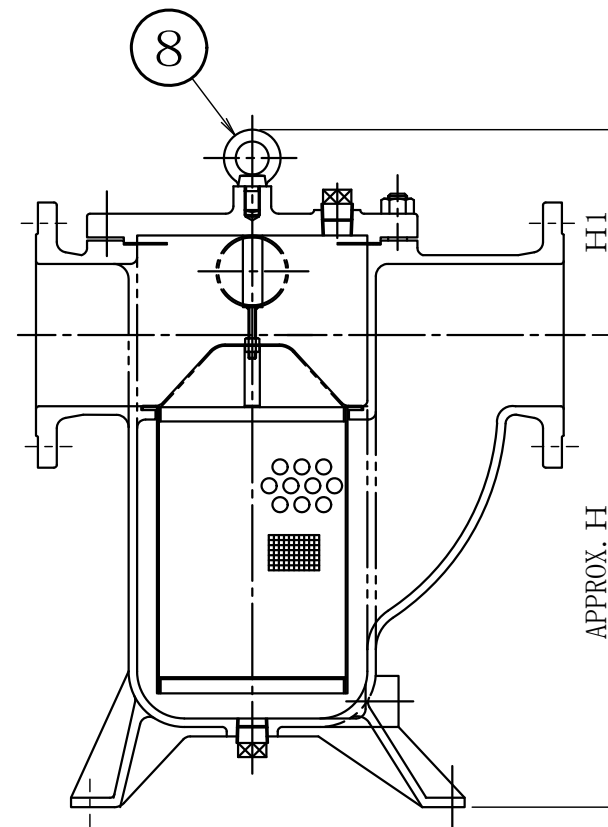

125A, 150A

SCREEN

	MESH
	20 MESH
	40 MESH
	60 MESH
	80 MESH
	100 MESH

No	NAME OF PART	MATERIAL	Q.T.Y	REMARKS
8	EYE BOLT	SUS304	1	
7	VENT PLUG	SUS316	1	
6	DRAIN PLUG	SUS316	1	
5	GASKET	T#9007-G20	1	
4	BOLT NUT	SUS304	SET	
3	SCREEN	SUS316	1	
2	COVER	SCS14A	1	
1	BODY	SCS14A	1	

NAME 10K
FLANGED U TYPE STRAINER

FLUID	TEST PRESSURE	TEST PRESSURE	SEAT	BODY
(HYD) 1.5 MPaG	1.0 MPaG		(HYD) MPaG	(HYD) 1.5 MPaG
(AIR) MPaG				
(HYD) MPaG	150 °C		(HYD) MPaG	(HYD) MPaG
(AIR) MPaG				

DRAWING MODEL No 10FUL-14A

DATE	A.P	C.K	D.S	D.W
OCT. 4, 2016	MORITA	MORITA	MORITA	MORITA

MM THREE-M INDUSTRY CO.,LTD.

No	DESCRIPTION	DATE	A.P	C.K	D.W
REVISIONS					