

14	Rivet	Aluminium	打込みねじ	A1056	1
13	Name Plate	Aluminium	銘板	A1050	1
12	Gasket	PTFE	ガスケット	PTFE	1
11	Gasket	PTFE	ガスケット	PTFE	2
10	Gasket	Non-Asbestos	ガスケット	Non-Asbestos	1
9	Cap	Ductile Cast Iron	キャップ	FCD450	1
8	Screen	Stainless Steel	スクリーン	SUS304	1
7	Heating Cover	Carbon Steel	保温カバー	SPC	1
6	Ring	Stainless Steel	リング	SUS303	1
5	Bi-Metal	-----	バイメタル	-----	1
4	Disc Cover	Cast Stainless Steel	ディスクカバー	SCS13	1
3	Disc	Stainless Steel	ディスク	SUS420J2	1
2	Valve Seat	Cast Stainless Steel	弁座	SCS2A	1
1	Body	Ductile Cast Iron	本体	FCD450	1
No.	Name of Parts	Material	部品名	材質	Q.TY

(mm)

Size	L	H ₁	H ₂	A	Screen		Flange JIS 20KFF					Weight (kg)
					ds	Hs	d	D	C	t	n-h	
15A	125	50	58	19	18	32	15	95	70	14	4-15	2.3
20A	140	53	63	22	20	35	20	100	75	16	4-15	3.4
25A	150	63	65	22	20	35	25	125	90	16	4-19	4.1

Specification	
Fluid	
Press.	MPa
Temp.	

TYPE TD-30NA STEAM TRAP
スチームトラップ

Approval	M. KUME
Check	H. TANGE
Drawing	T. SHINJO
Drawing No.	Y-1016-5109
Date	10 MAY. 2005



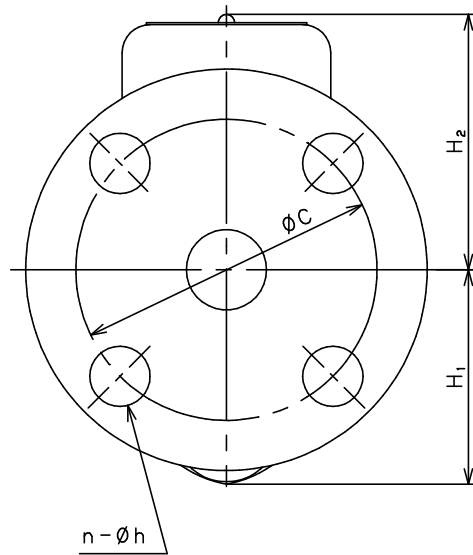
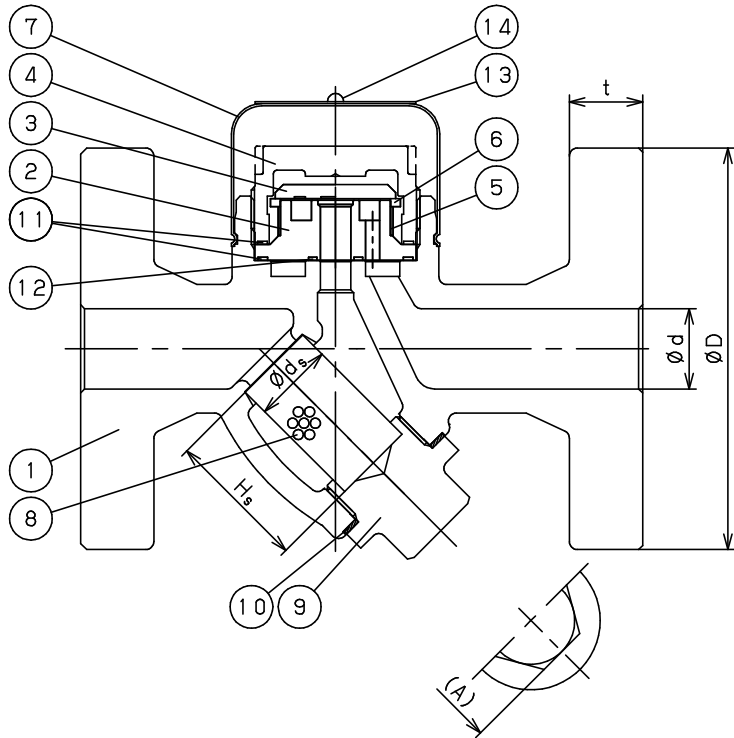
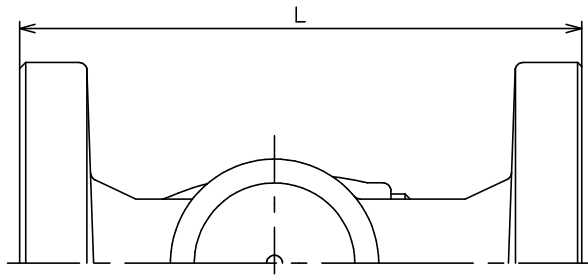

14	Rivet	Aluminium	打込みねじ	A1056	1
13	Name Plate	Aluminium	銘板	A1050	1
12	Gasket	PTFE	ガスケット	PTFE	1
11	Gasket	PTFE	ガスケット	PTFE	2
10	Gasket	Non-Asbestos	ガスケット	Non-Asbestos	1
9	Cap	Ductile Cast Iron	キャップ	FCD450	1
8	Screen	Stainless Steel	スクリーン	SUS304	1
7	Heating Cover	Carbon Steel	保温カバー	SPC	1
6	Ring	Stainless Steel	リング	SUS303	1
5	Bi-Metal	-----	バイメタル	-----	1
4	Disc Cover	Cast Stainless Steel	ディスクカバー	SCS13	1
3	Disc	Stainless Steel	ディスク	SUS420J2	1
2	Valve Seat	Cast Stainless Steel	弁座	SCS2A	1
1	Body	Ductile Cast Iron	本体	FCD450	1
No.	Name of Parts	Material	部品名	材質	Q.TY

TYPE TD-30NA STEAM TRAP
スチームトラップ

Approval	M. KUME
Check	H. TANGE
Drawing	T. SHINJO
Drawing No.	Y-1016-5105
Date	10 MAY. 2005



Size	L	H ₁	H ₂	A	Screen		Flange JIS 10KFF					Weight (kg)
					ds	Hs	d	D	C	t	n-h	
15A	125	50	58	19	18	32	15	95	70	14	4-15	2.3
20A	140	53	63	22	20	35	20	100	75	16	4-15	3.4
25A	150	63	65	22	20	35	25	125	90	16	4-19	4.1

Thickness of Flange : t=JIS 20K

Specification	
Fluid	
Press.	MPa
Temp.	